

CI/SfB reference

(76.4)

Xh 4

JANUARY 1998

# teborax<sup>®</sup>

aluminium shelving brackets

PRODUCT CATALOGUE

## Origins

Designed by a Swede, Evar Bergström, 'Tebrax' brackets were first made in London in 1954, Tebrax Ltd. being formed in 1957. Tested by the National Physical Laboratory, featured by the Design Council in the original Design Index at the Design Centre, the 'Tebrax' aluminium shelving bracket system has evolved during the years to reflect market requirements and the advance of technology. What appears to be a simple product conceals a continuing programme of detail improvement.

## The 'Tebrax' Adjustable Aluminium Shelving Bracket System

The 'Tebrax' system comprises aluminium brackets and uprights, ancillary items made from varying materials. The aluminium components are strong, unobtrusive and versatile. They will support a wide variety of shelving materials in common use - wood, glass, metal and plastic. Panel support uprights will hold mirrors or panels for decorative or concealment purposes. Floor to ceiling installations and free standing island or gondola units are based on steel carcasses to which the aluminium components are fitted. The advantages are greater strength plus the flexibility of the large aluminium component range. Special components and finishes are available for commercial quantities. All sizes are nominal.

## Uprights – Pages 3-4

There are three aluminium uprights, slotted to allow non slip bracket adjustability in 25mm steps. These uprights are available in nominal 305mm multiples up to a maximum length of 3660mm in certain cases. Floor to ceiling installations and island/gondola units require the use of aluminium or steel re-inforcing sections. Strong island units up to 2300mm high are readily achievable.

## Brackets – Pages 5-7

Nine bracket types are available for shelves from 100mm to 600mm deep. **The bracket Order Codes include the shelf depth in centimetres.** For example, a W30 bracket is a Type W bracket for a 300mm deep wooden shelf.

## Finishes

Aluminium components: Satin – Flash anodised self-colour – a matt silver appearance.

Powder Coated colours: Antique Gold, Black and Warm White. (Other colours in commercial quantities.)

Steel components: Powder Coated – matching the aluminium components. (Grey to match Satin components.)

Plastic components: Self colour.

Pressure pads: Grey or Black.

## Prices, Quotations and Orders

Price Lists, trade terms, quotations, pro-forma invoices, samples and technical information are obtainable from Tebrax Ltd. on request. To ensure accuracy, only written orders are actioned, Fax being recommended to save time. Orders are transmitted by computer to the warehouse, from which all goods are despatched. An express delivery service is used except for small packets which are despatched by other means. Special delivery methods can be used at extra cost or goods collected – by prior arrangement only.

Tebrax Ltd. quotes for special items and finishes. Please remember that it takes time to produce a new tool and that trade finishers charge for minimum batches or non-stock colours. Work well ahead and order one large batch rather than a number of smaller ones to optimise the cost of special components.

Mill finish components can be supplied at Satin finish prices to special order for customers to finish as they please. The Mill finish is not a stock item so that delivery will vary.



## Accessories

### Board Angles - Page 8

to support notice/display/blackboards

### Bookends - Page 8

Solid – Small, Medium & Large. Open – Small & Large

### Centre and End Clips - Page 7

of Plastic for abutting glass shelves, or at the ends of glass shelves on Type FG brackets

### Counter Angles - Page 8

for holding short lengths of upright in display cases

### Hanging Rail Clamps - Page 6

### Metal Glass Clamps - Page 8

to clamp the rear of glass shelves subject to tilting (for example when spirit optics are clamped to the front of glass shelves in bars)

Placing orders and obtaining quotations is straightforward if the following information is available: item, size, finish and quantity. 'Tebrax' short form order codes contain this information except for quantities.

**Upright Codes = Section Type + Length** (in mm rounded up)

**Nominal Lengths (in mm)**

	305	610	915	1220	1525	1830	2135	2440	2745	3050	3355	3660
<b>Types</b>												
<b>Support</b>	S03	S06	S09	S12	S15	S18	S21	S24	S27	S30	S33	S36
<b>6P Panel Support</b>	6P03	6P06	6P09	6P12	6P15	6P18	6P21	6P24	6P27	6P30	6P33	6P36
<b>12P Panel Support</b>	12P03	12P06	12P09	12P12	12P15	12P18	12P21	12P24	12P27	12P30	12P33	12P36

**Bracket Codes = Bracket Type + Shelf Depth** (in centimetres)

<b>Types</b>												
<b>FG</b>	FG15	FG20	FG25	FG30	FG35	FG40	FG45	FG50	FG55	FG60		
<b>G</b>	G15	G20	G25	G30	G35	G40	G45	G50	G55	G60		
<b>QW</b>	QW15	QW20	QW25	QW30	QW35	QW40	QW45	QW50	QW55	QW60		
<b>SG</b>	SG10	SG15	SG20	SG25	SG30							
<b>SW</b>	SW10	SW15	SW20	SW25	SW30							
<b>W</b>	W15	W20	W25	W30	W35	W40	W45	W50	W55	W60		
<b>15U</b>	15U15	15U20	15U25	15U30	15U35	15U40	15U45	15U50	15U55	15U60		
<b>20D</b>	20D15	20D20	20D25	20D30	20D35	20D40	20D45	20D50	20D55	20D60		
<b>60D</b>				60D30								

**Finishes are added as the final part of the Codes**

Antique Gold = AG	Black = BK	Satin = S	Warm White = WW
Powder Coated	Powder Coated	Anodised	Powder Coated

## Examples

- S12S** - Type S upright - 1220mm long - Satin finish
- 6P24AG** - Type 6P upright - 2440mm long - Antique Gold powder coated finish
- W15S** - Type W bracket - for 15cm deep wood shelf - Satin finish
- G50WW** - Type G bracket - for 50cm deep glass shelf - Warm White powder coated finish

## Sizes and Tolerances

All sizes are nominal and upright lengths are subject to cutting tolerances of +/- 5mm.

## Aluminium Alloys

Aluminium components are made from fully heat treated magnesium/silicon alloys to BS 1474:1987.

## Strength and Loading Tests

'Tebrax' tests indicate that standard 25mm wide brackets will carry up to 90kg . . . and slim brackets 15mm wide will carry up to 22kg . . . distributed weight per pair of brackets in both cases including a margin for shock loading i.e. for weights dropped from a height .\*\*\*\* Strength figures are meaningless unless they are related to systematic testing to destruction by a recognised authority. (The reason why the original 'Tebrax' tests were done by the Government's National Physical Laboratory.) Much then depends on any allowance given for the effects of shock loading. You can do your own destruction test of any bracket system for comparison purposes. Choose a one metre wide shelf which is strong enough not to bend. screwing it to two brackets. Apply distributed weight to the shelf until a shelving component fails. Then decide what percentage of the failure load represents a reasonable safe working maximum distributed load. (Commercial loading tests are commonly done with girders as shelves and lead shot as the load.)\*\*\*\* Do not forget to test your shelving materials! Shelves which sag or break are to be avoided. \*\*\*\* Your loading tests will reveal the suitability of your chosen shelving material at specific bracket (and therefore upright centre to centre spacings) spacings. The economic cost of a shelving installation is based on the compromise of the specification of the shelving material used versus the number of brackets required for a safe loading capacity.\*\*\*\* Weaker shelves or heavier loadings will require more brackets/uprights. Optimise your shelving costs to your advantage by testing your shelving materials before specifying your bracket requirements.

## Support – S

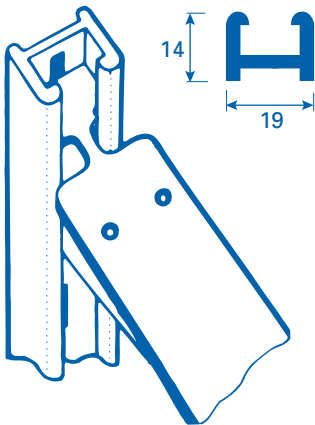

This is the basic wall mounting upright which holds all brackets, clips etc. Fixing: No 8 countersunk screws spaced 101mm apart. Available in 305mm multiples up to a maximum length of 3660mm.

## 6mm Panel Support – 6P

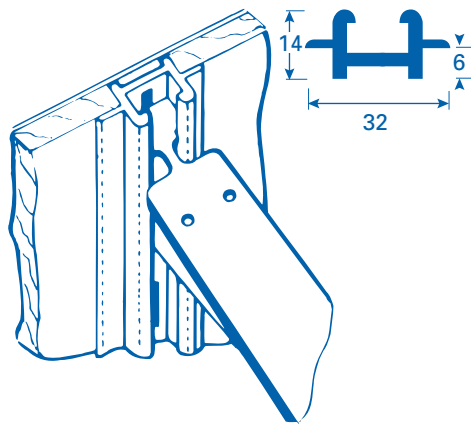

This upright holds 6mm mirrors or panels against a wall. Other details are similar to type S upright. Available in 305mm multiples up to a maximum length of 3660mm.

## 12mm Panel Support – 12P

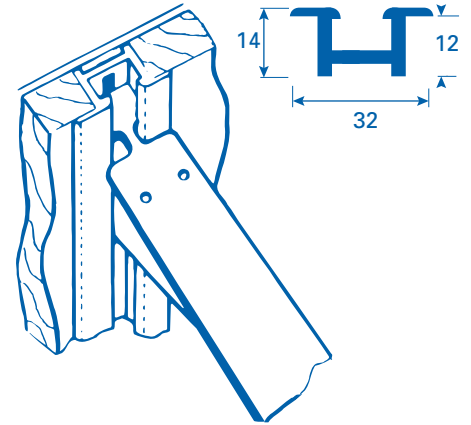

This upright holds 12mm thick panels against a wall. Other details are similar to type S upright. Available in 305mm multiples up to a maximum length of 3660mm.

## Small re-inforced upright

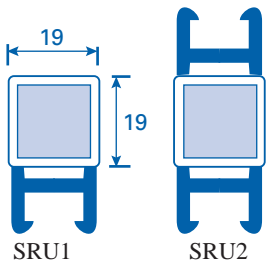

Small re-inforced uprights consist of a steel hollow section to which one or two aluminium uprights of any type are screwed. SRU1 is the single sided version. SRU2 is the double sided version. Available to order up to a maximum length of 1830mm.

## Medium re-inforced upright

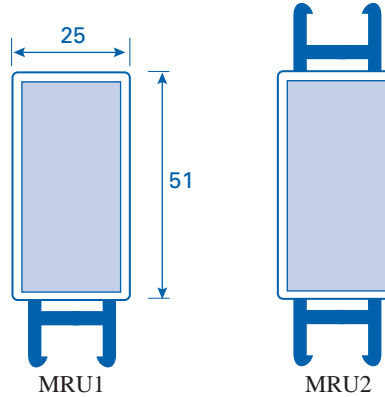

Medium steel re-inforced uprights consist of a steel hollow section to which one or two aluminium uprights of any type are screwed. MRU1 is the single sided version. MRU2 is the double sided version. Available to order up to a maximum length of 2745mm.

## Small Adjustable End Plate

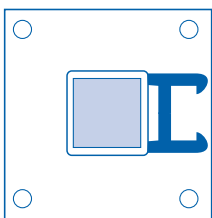

Maximum height 1830mm if supported at top and bottom

**For SRU1 and SRU2**  
SAP – Adjustable end plate  
SFP – Fixed end plate

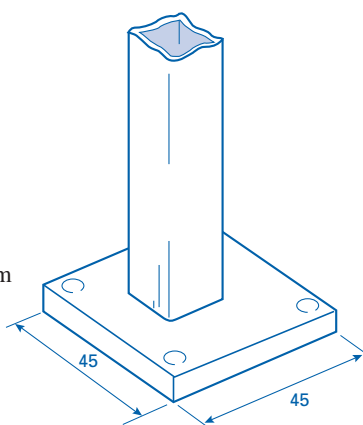

## Medium Adjustable End Plate

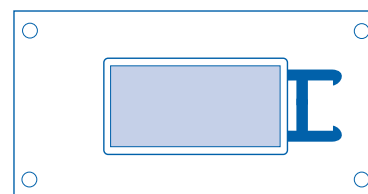

Maximum height 2745mm if supported at top and bottom

**For MRU1 and MRU2**  
MAP – Adjustable end plate  
MFP – Fixed end plate

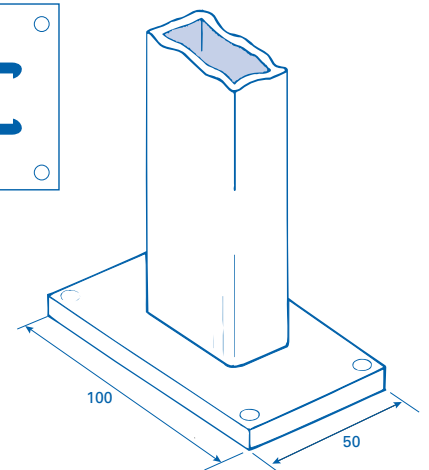

Internal or 'invisible' end fittings are available:  
SIP – Small invisible plate      MIP – Medium invisible plate

**SGON**  
**Single Sided Gondola**  
**Maximum height 2300mm**

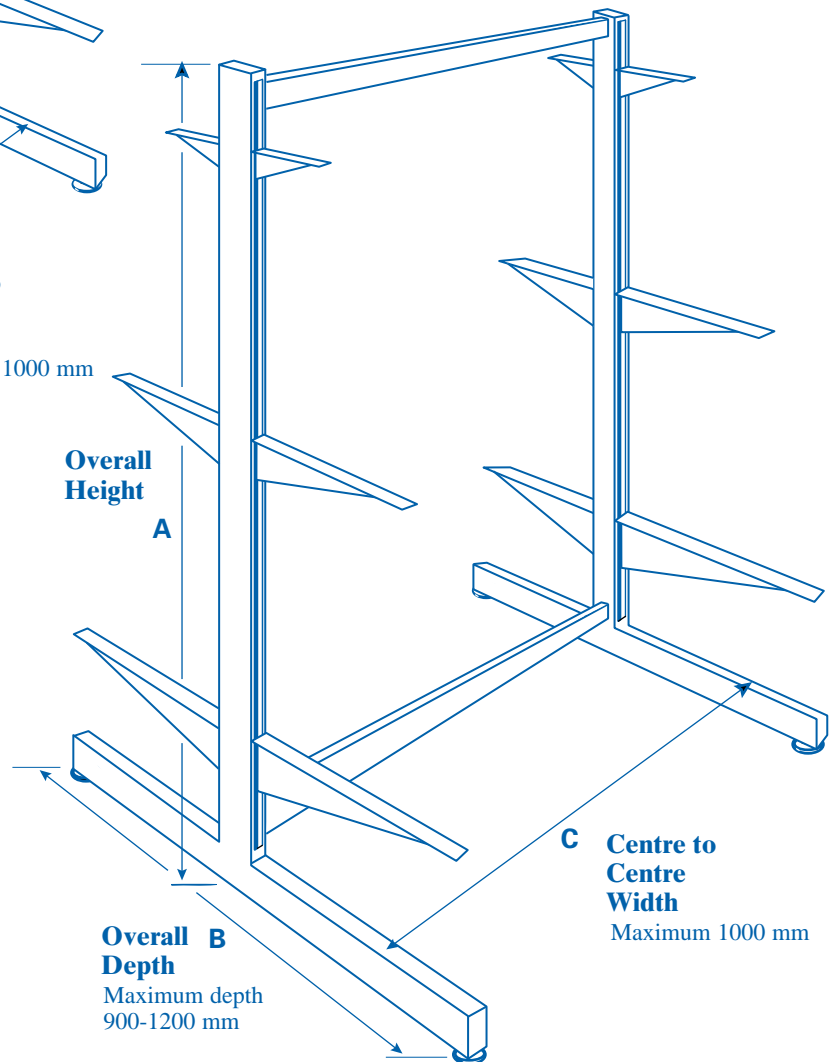
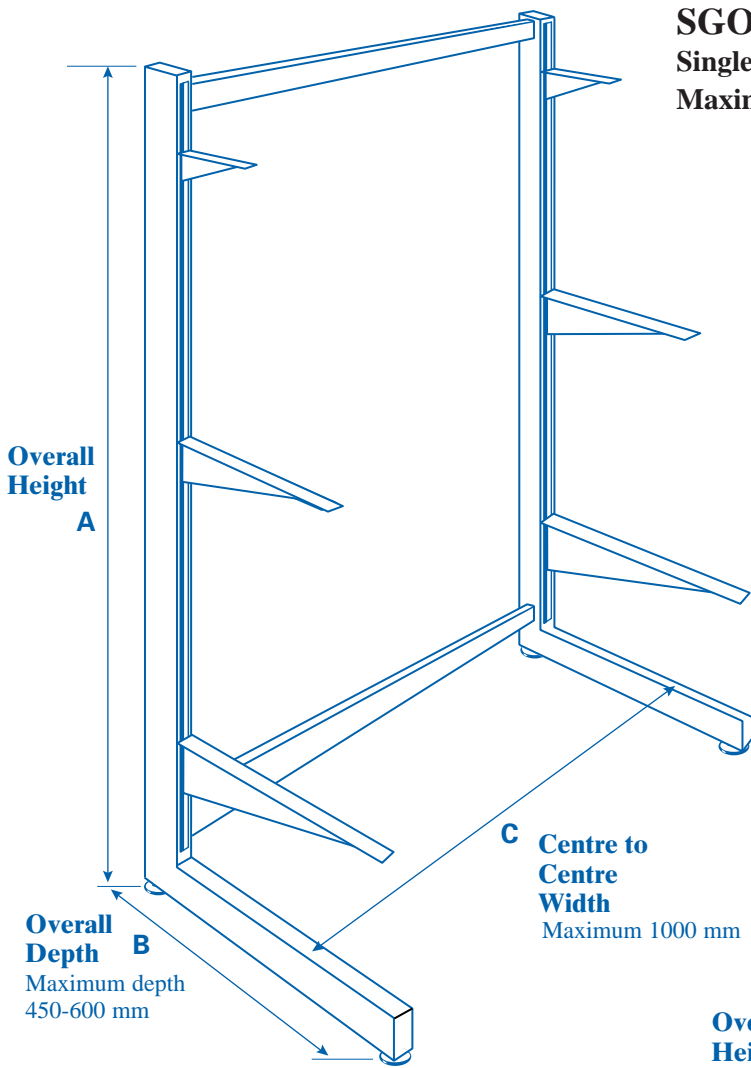

**DGON**  
**Double Sided Gondola**  
**Maximum height 2300mm**

Two gondola types are available to order in KD form, MRU1 and MRU2 uprights carrying Support/Panel Support uprights and brackets. Dimensions are variable to order, 1000mm centre to centre maximum spacing between uprights being recommended. Both types can be extended with further units as necessary. Gondolas are supplied without shelves or back panels. Steel components are powder coated to match the aluminium powder coated colours – Grey in the case of Satin. Typical ex-works delivery: 21/28 days.

Quotations: Please specify SGON or DGON: A and B dimensions are overall dimensions; C dimensions are centre to centre dimensions; aluminium uprights and brackets required; finish – and number of gondola units required. Quotations are available within a day or two.

# Brackets for wood shelves

All dimensions are in mm.

## Type W

### Brackets for level wood shelves

Ten sizes in increments of 50mm to carry 150-600mm wide shelves. Brackets have four fixing holes for round-headed No 6 screws: two holes are normally sufficient but use four when two shelves meet on the bracket

(ST studs enable these brackets to support glass shelves. See page 8.)

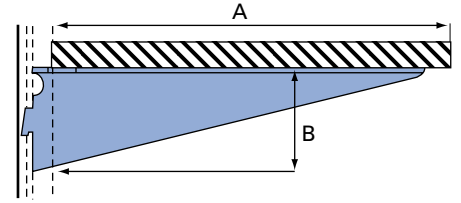
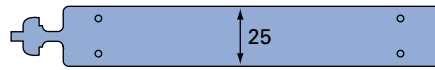

Sizes:	W15	W20	W25	W30	W35	W40	W45	W50	W55	W60
Width A	150	200	250	300	350	400	450	500	550	600
Depth B	41	41	41	55	55	66	66	89	89	89

## Type SW

### Brackets for small level wood shelves

Five sizes in increments of 50mm to carry 100-300mm wide shelves. The maximum load is 22kg per pair distributed weight. Brackets have one fixing hole for a round-headed No 6 screw.

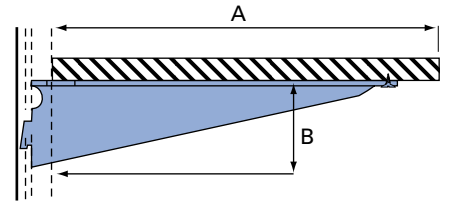

Sizes:	SW10	SW15	SW20	SW25	SW30
Width A	100	150	200	250	300
Depth B	41	41	41	41	41

## Type QW

### Brackets for quick release level wood shelves

Ten sizes in increments of 50mm to carry 150-600mm wide shelves. Wider shelves can be slotted or grooved to overhang as illustrated.

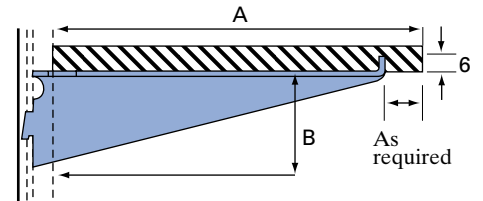

G brackets support glass shelves in 50mm increments. QW brackets will support intermediate glass shelf sizes.

Sizes:	QW15	QW20	QW25	QW30	QW35	QW40	QW45	QW50	QW55	QW60
Width A	150	200	250	300	350	400	450	500	550	600
Depth B	41	41	41	55	55	66	66	89	89	89

## Type 15U

### Brackets for 15° upwards sloping wood shelves

Ten sizes in increments of 50mm to carry 150-600mm wide shelves. Brackets have four fixing holes for round-headed No 6 screws; two holes are normally sufficient but use four when two shelves meet on a bracket.

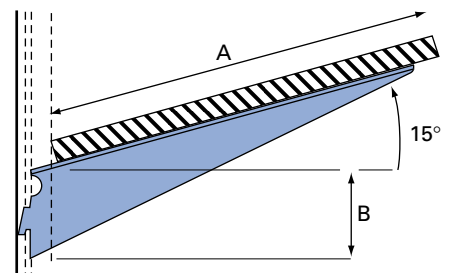
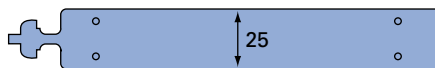

Sizes:	15U15	15U20	15U25	15U30	15U35	15U40	15U45	15U50	15U55	15U60
Width A	150	200	250	300	350	400	450	500	550	600
Depth B	41	41	41	55	55	66	66	89	89	89

## Type 20D

### Brackets for 20° downward sloping wood shelves

Ten sizes in increments of 50mm to carry 150-600mm wide shelves. Brackets have four fixing holes for round-headed No 6 screws: two holes are normally sufficient but use four when two shelves meet on a bracket. Downward sloping wood shelves require a lip along the bottom edge.

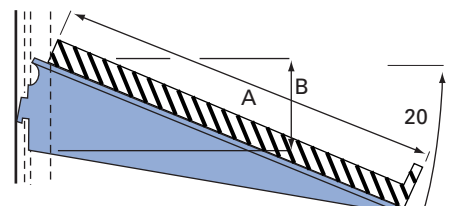

Sizes:	20D15	20D20	20D25	20D30	20D35	20D40	20D45	20D50	20D55	20D60
Width A	150	200	250	300	350	400	450	500	550	600
Depth B	41	41	41	55	55	66	66	89	89	89

# Brackets for 60° shelves and canopies

All dimensions are in mm.

## Type 60D30

### Brackets for 60° downward sloping wood shelves

One size only to carry a 300mm wide (or wider) shelf. Brackets have two pilot holes at the top for self-tapping screws fixed through the shelf material, plus two additional fixing holes for round-headed No 6 screws to provide fixing from the rear of the shelf. Downward sloping wood shelves require a lip along the bottom edge.

Larger sizes to order.

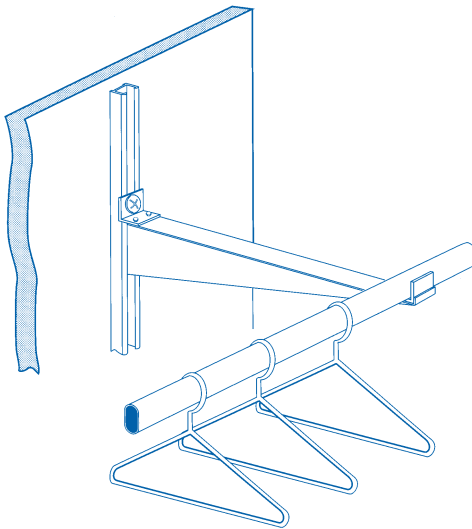
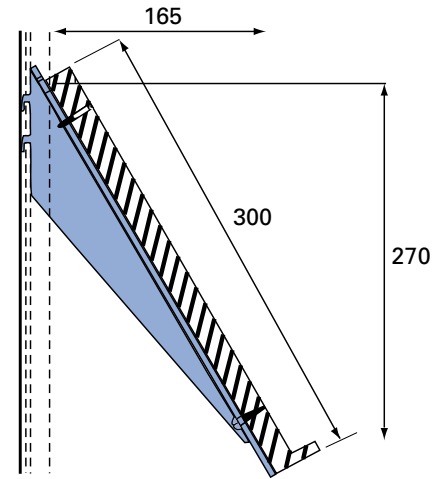

**HC**  
Two Clamps to carry HR rail (15 x 30x3050)  
on Type QW brackets

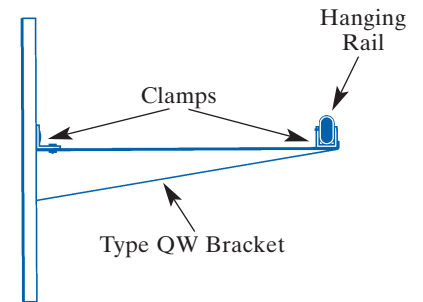

# Brackets for glass shelves

All dimensions are in mm.

## Type G

### Brackets for level glass shelves

Ten sizes in increments of 50mm to carry 150-600mm wide shelves.

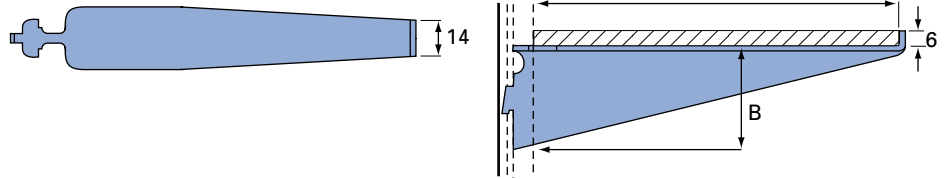

Sizes:	G15	G20	G25	G30	G35	G40	G45	G50	G55	G60
Width A	150	200	250	300	350	400	450	500	550	600
Depth B	41	41	41	55	55	66	66	89	89	89

## Type SG

### Brackets for small level glass shelves

Five sizes in increments of 50mm to carry 100-300mm wide shelves. The maximum load is 22kg per pair distributed weight.

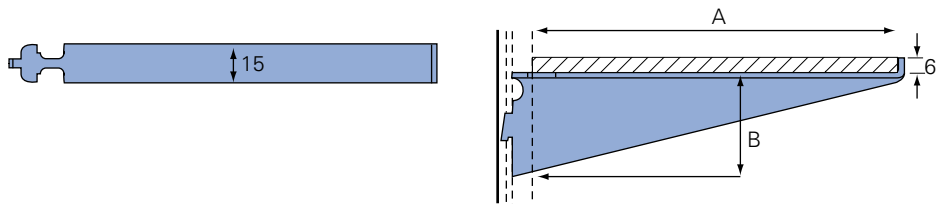

Sizes:	SG10	SG15	SG20	SG25	SG30
Width A	100	150	200	250	300
Depth B	41	41	41	41	41

## Type FG

### Brackets for level glass shelves with or without Centre/End clips

Ten sizes in increments of 50mm to carry 150-600mm wide shelves. This is a non-tapering version of type G bracket. Two glass shelves can meet at Centre Clips. (Use two or three per bracket.) End Clips at shelf ends lessen sideways shelf movement.

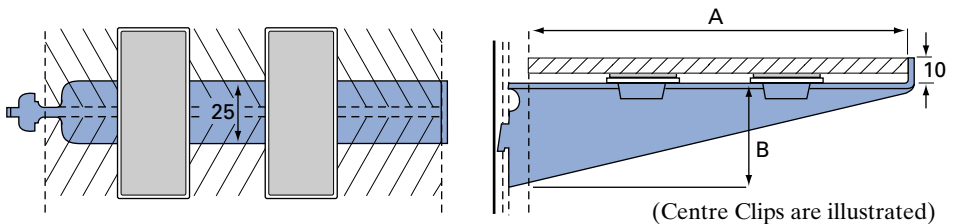

Sizes:	FG15	FG20	FG25	FG30	FG35	FG40	FG45	FG50	FG55	FG60
Width A	150	200	250	300	350	400	450	500	550	600
Depth B	41	41	41	55	55	66	66	89	89	89

## Centre Clips – CC

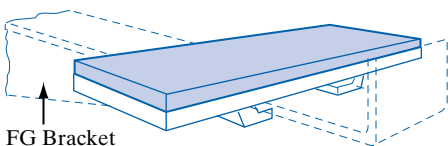
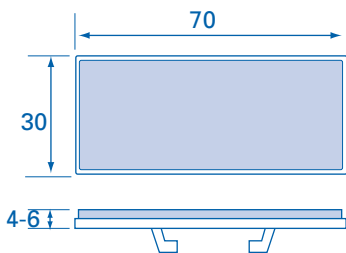

## For Glass Shelves

Plastic CC and EC clips can be used with any 25mm wide brackets: Type W etc.

## End Clips – EC

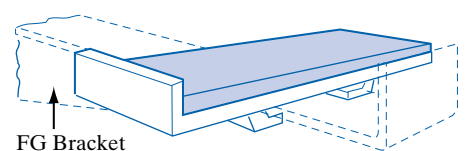
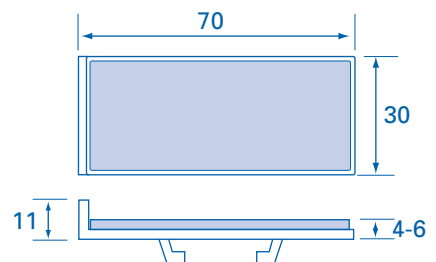

## Board Angle – BA

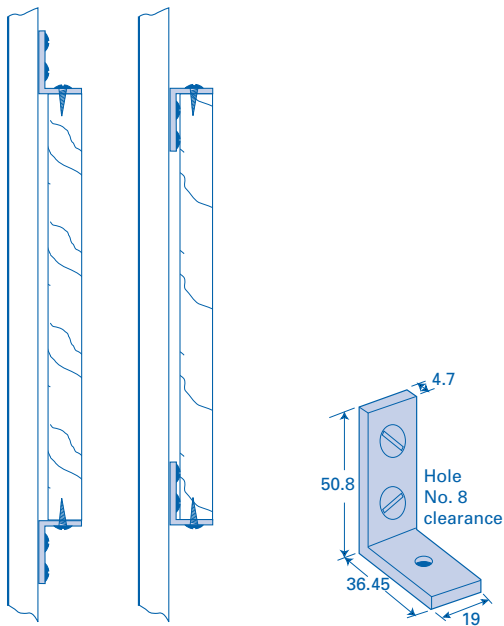

Board Angles are used above and below notice/display/blackboards up to 25mm thick. Two M6 nuts and bolts are supplied.

## Counter Angle – CA

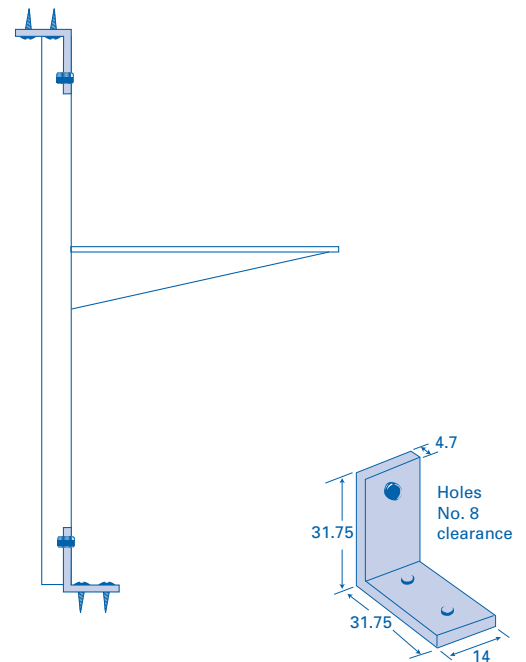

Counter Angles provide front/rear facing end and fittings for short lengths of S, 6P and 12P uprights in counter/display cases or where back fixing is impracticable. One Alan headed screw is provided.

## Fascia Board Angles

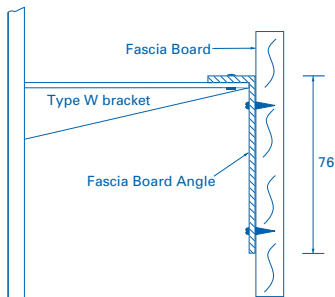

Fascia Board Angles are bolted to any Type W bracket to carry fascia boards. Two nuts and bolts are provided.

## Metal glass clamp – MGC

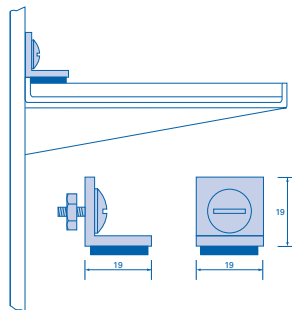

These items clamp the rear of glass shelves to prevent tipping when used with optics. One M6 nut and bolt are provided.

## Type ST Studs

To support glass shelves on Type W brackets

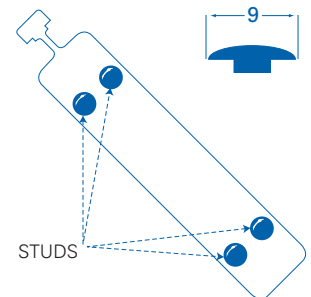

## Solid Bookends

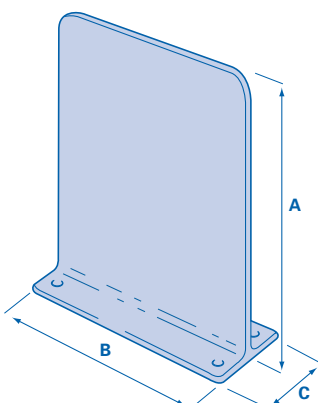

**Order Codes**  
 BSS Small  
 BSM Medium  
 BSL Large  
 Four 5mm diameter fixing holes.

Sizes:	A	B	C
BSS	125	95	37
BSM	125	190	37
BSL	203	152	50

## Open Bookends

**Order Codes**  
 SOB Small  
 LOB Large  
 Four 5mm diameter fixing holes.

Sizes:	A	B	C
Small SOB	124	125	37
Large LOB	203	203	50

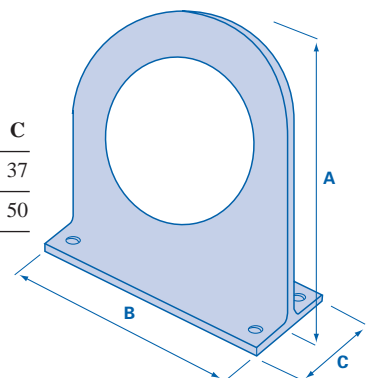

# Fixing

## Fixing upright supports

All wall-mounting upright supports are sold in nominal multiples of 305mm, but the lengths can vary slightly due to normal cutting tolerances. The spacing between uprights can be between 600mm and 1000mm depending on the anticipated shelf loading. The uprights must be vertical and parallel to each other to ensure level shelves. Use the top fixing hole in each upright as an alignment point.

First mark with an 'X' where the top fixing hole of the centre or left hand upright is to be drilled. From this point use a spirit level to mark the position of the top fixing hole of the next upright at the desired spacing.

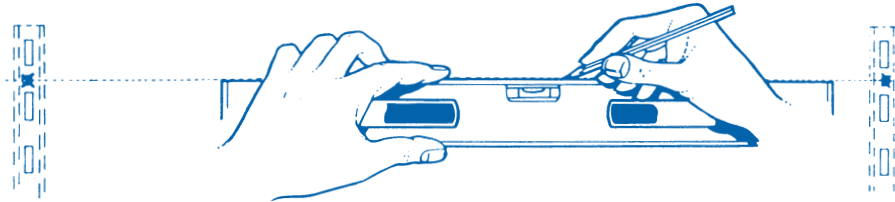

Next drill and plug the wall. (Slow drill speeds are to be preferred - the bits stay sharp longer and provide a better key for plugging.) Insert the top screws in each upright, leaving slightly slack. Line up the first upright to true vertical position, using a spirit level or plumb line and insert the bottom screw. Follow the same procedure for the remaining uprights, checking the distance between each top and bottom to ensure that they are parallel. Tighten the screws before marking out the positions of any intermediate fixings that are required. Additional screws will normally be needed for heavy loadings. When using panel support uprights, use the panel to align the uprights and ensure the squareness of the installation.

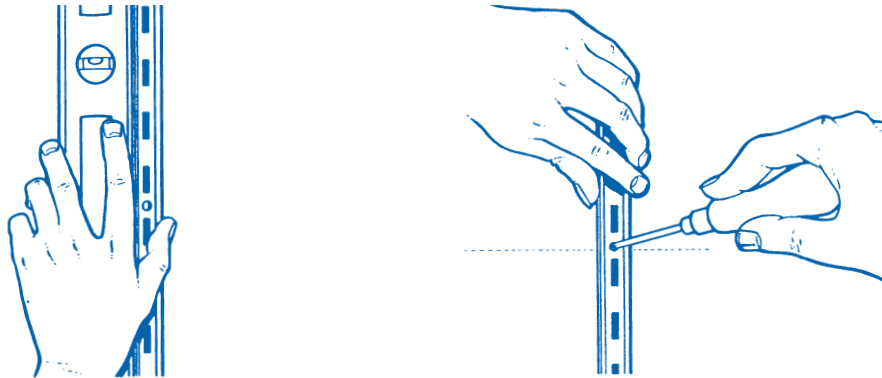

Use No 8 countersunk screws (Supascrews are recommended). The shelves should be fixed in position tight up to the uprights, or rebated round them to press against the wall.

For wooden shelves on type W brackets use two fixing screw (No 6 round-headed), one at the front and one at the rear. Use all four fixing holes where two shelves meet on a bracket. Glass shelves must be cut accurately to fit type G, SG or FG brackets.

## Fixing brackets

1. Brackets can be fitted directly into the front of the support upright. The bracket should be held at the broadest part and the bracket head placed sideways into the upright.
2. Twist the bracket upright, tilting the front end up, then down to locate in the required slot.
3. Finally press down gently to lock into position. The slight sideways play (due to the necessary clearance dimensions) is eliminated when the shelves are fitted.

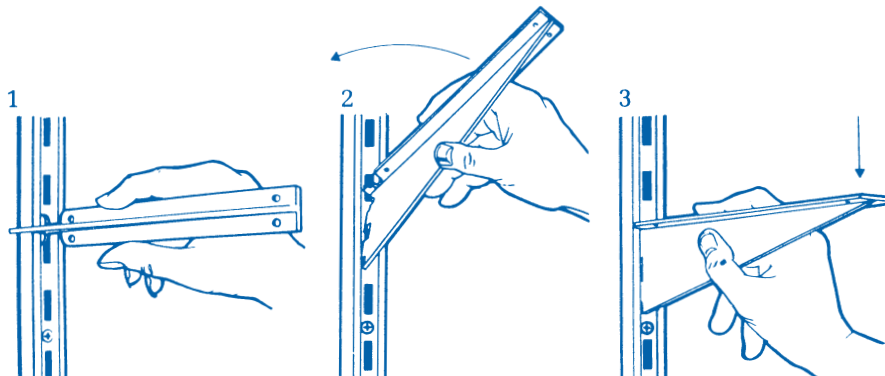

## Trade Descriptions Act 1968

Every care is taken to ensure that the information given in this Catalogue is correct and up to date but it is not intended to form part of any contract. In view of changes which are made from time to time to the materials, dimensions and specifications of 'Tebrax' products, intending purchasers should verify with the Company whether any such changes have taken place. No warranty is intended to be given in respect of these contents. This Product Catalogue replaces all earlier literature from the 1st January 1998. World Copyright 1998. Reproduction in any form is expressly forbidden without specific written permission from Tebrax Ltd.

**'Tebrax' is a Registered Trade Mark**



